



Important: When installed in the United States, the electrical wiring of this spa must meet the requirements of the National Electric Code (NEC) and any applicable state or local codes. The electrical circuit must be installed by an electrical contractor AND approved by a local building/electrical inspector.

Power Configurations for 780 Dover Models (North America, 60 Hz)

This section describes the three power configuration choices (Standard 15 Amp, Alternate 30 Amp, or Alternate 40 Amp) for Dover hot tub models.

Note

Wire size must meet NEC recommendations and is determined by maximum current draw and length or run.

Important: All of the alternative electrical configurations require a qualified technician to perform minor circuit board modifications. To avoid damage to the spa, do not activate power to the spa until these modifications have been made. We recommend Square-D or Cutler Hammer circuit breakers.

Config. #1	<p>Standard 15A Configuration (factory setting)</p> <ul style="list-style-type: none">• 120 VAC/15A 3-wire configuration (hot, neutral, and ground)• 1 kW heater output• Use either the 15A GFCI power cord (supplied only for US models) or a 15A single-pole GFCI breaker (not supplied)• Maximum electrical current draw of 12A	<p>In this Standard 15A configuration, the heater does not operate if the high-speed jets pump is activated.</p> <p>Place the spa within 10 ft (3m) of a dedicated grounded, grounding-type electrical outlet so that the power cord supplied with the spa can be plugged directly into it. Use the power cord shipped from the factory. Using another power cord may void the warranty.</p> <p>If the spa is more than 10 ft (3m) from an outlet, it must be hard wired to a 15A single-pole GFCI breaker.</p>
Config. #2	<p>Alternate 30A Configuration</p> <ul style="list-style-type: none">• 240 VAC/30A 4-wire configuration (2 hots, neutral, and ground)• 4 kW heater output• 30A dual-pole GFCI breaker (not supplied)• Maximum electrical current draw of 21A	<p>If your home does not have 240 VAC/40A power available, connect the spa to a 240 VAC/30A power source. Then, have a qualified electrician modify the circuit board to match the power source.</p> <p>In this configuration, the heater yields the same rapid temperature rise as in the 40A configuration. However, the heater does not operate at the same time the high-speed jets pump is operating.</p>
Config. #3	<p>Alternate 40A Configuration</p> <ul style="list-style-type: none">• 240 VAC/40A 4-wire configuration (2 hots, neutral, and ground)• 4 kW heater output• 40A dual-pole GFCI breaker (hard wired only)• Maximum electrical current draw of 30A	<p>In the Alternate 40A configuration, the heater does operate at the same time the high-speed jets pump is operating. It is necessary to have a qualified electrician modify the circuit board.</p>

Electrical Tasks After Spa Delivery



Important safety information for all spa models

Proper grounding is extremely important. This spa is equipped with a Current Collector system. A pressure securing wire connector is provided on the outside of the load box to permit connection of a bonding wire between the spa and any metal within 5 ft. (1.5m) of the spa. Bonding wire must be at least #8 AWG (8.4 mm²) solid copper wire.

After the spa is placed in the specified location, the electrician must perform the tasks listed below to complete the electrical installation. Give this information to the electrician when he begins to install your spa.

Task	Action
1	To gain access to the spa's power terminal strip, remove the spa cabinet panel on the side of the spa under the control panel (see Figure 3 on the next page). After removing the spa cabinet panel, remove the four metal control box cover screws and metal control box cover.
2	Locate the power supply inlet (front of the spa near the base). Select the inlet you want to use, then feed the power cable through to the control box.
3	Insert the power cable through the large opening provided on the left-side of the metal control box.
4	Connect the wires, color to color, on the terminal strips and tighten securely.
5	To complete the electrical installation, secure the metal control box door by replacing its 4 screws, then re-install the spa cabinet panel under the control panel.

For specific electrical information about the spa model being installed, look through Figures 3 through 9 in this section.

Electrical Tasks After Spa Delivery, Continued

Installing a 3-Wire 120 VAC or 4-Wire 120/240 VAC Connection for 780 Dover Models, 680 Denali, Tacoma Models

Figure 6 The Spa Equipment Compartment (spa features subject to change without notice. Pumps location vary by model)

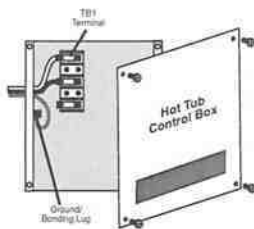
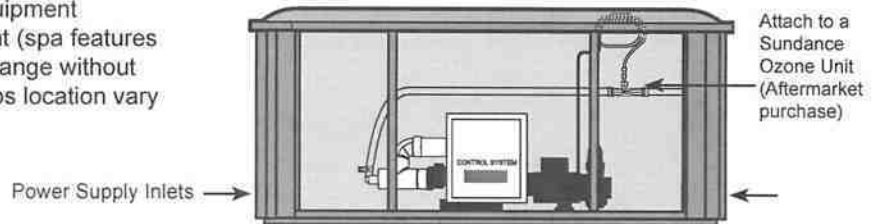

Note: TB1 terminal location will vary between models

Figure 7 The Control Box for Denali, Dover, and Tacoma Models

The 3-wire, 120 VAC connection is illustrated. The location of the TB1 terminal may vary between models.

Figure 8 Standard 3-wire, 120 VAC connection for Denali, Dover and Tacoma models.

Use the supplied GFCI cord for installations in the USA. Otherwise, hard wire a 3-wire connection.

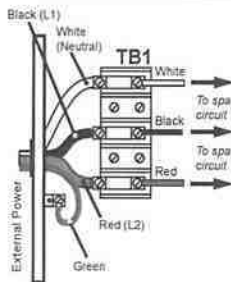
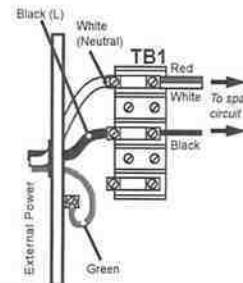

Figure 9 Standard 4-wire, 240/120 VAC connection for Denali, Dover and Tacoma models. Move red wire to terminal position #3 as shown. (Hard wired connections only).

Connection Configuration #2 120 VAC Connections for Denali, Dover, Tacoma Models (North America 60 Hz)

If the supplied 10 ft GFCI power cord (US only) cannot reach a dedicated, grounded wall outlet, it is necessary to install a 3-wire, hard-wired connection. These diagrams illustrate that configuration.

For enhanced heater performance the use of a 4-wire power connection is necessary.

A pressure sensitive terminal block (bonding lug) is attached to the outside surface of the load box. This permits the connection of a bonding wire between this point and any metal equipment chassis, metal water pipe, or metal conduit within 5 ft (1.5m) of the spa. The bonding wire must be at least a #8 AWG (8.4 mm²) solid copper wire.

1-Pole Circuit Breaker with 3-Wire Grounded Load Connection
(3 Wires to Hot Tub, 1-Hot (L), 1-Neutral (N), 1-Ground)

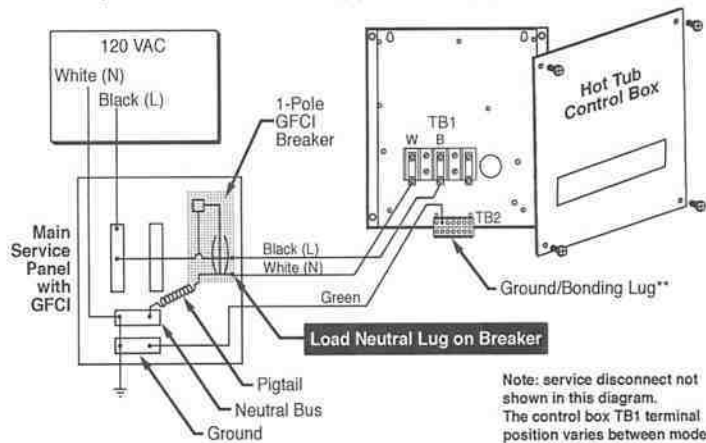

Main Panel with Secondary GFCI Shut-Off Box Using a 1-Pole GFCI Breaker with 3-Wire Grounded Connection
(3 Wires to Hot Tub, 1-Hot (L), 1-Neutral (N), 1-Ground)

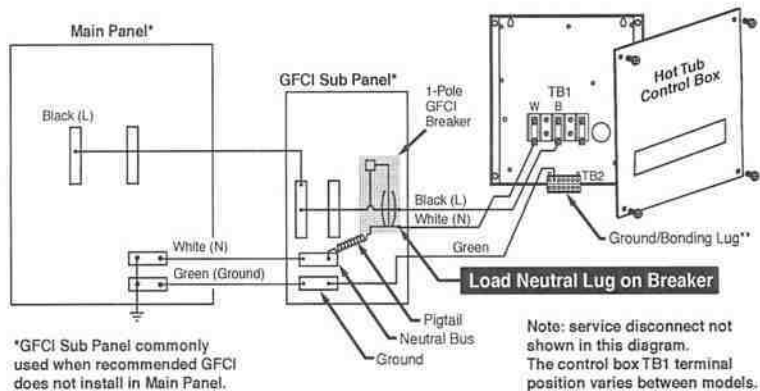

Connection Configuration #3 240 VAC Connections for Denali, Dover, Tacoma Models (North America 60 Hz)

A pressure sensitive terminal block (bonding lug) is attached to the outside surface of the load box. This permits the connection of a bonding wire between this point and any metal equipment chassis, metal water pipe, or metal conduit within 5 ft (1.5m) of the spa. The bonding wire must be at least #8 AWG (8.4 mm²) solid copper wire.

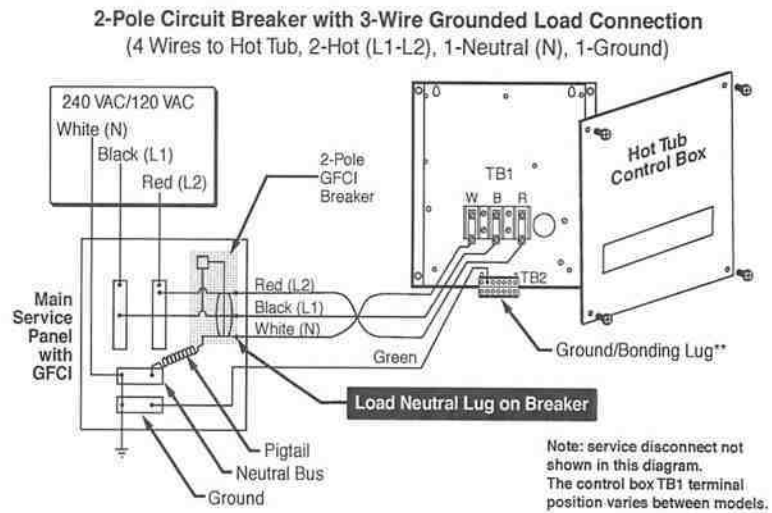

Main Panel with Secondary GFCI Shut-Off Box Using a 2-Pole GFCI Breaker with 3-Wire Grounded Connection

(4 Wires to Hot Tub, 2-Hot (L1-L2), 1-Neutral (N), 1-Ground)

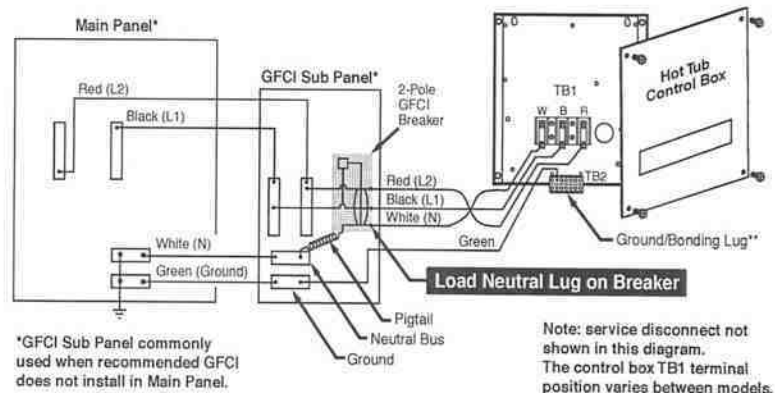

Final Electrical Connections

Now, you can have the final electrical connections made to your spa. Various wiring diagrams are illustrated on the next few pages. Each spa model has a slightly different configuration, so use the chart below to find the configuration for your spa.

Configuration #	Details
1	240 VAC Connections for North America 60 Hz: <ul style="list-style-type: none">• 880 Altamar, Cameo, Capri, Majesta, Marin, Optima, Maxxus Models• 780 Camden, Certa, Chelsee, Hamilton Models• Elite Constance, Victoria Models• 680 Burlington, Hartford, Hawthorne Models
2	120 VAC Connections for North America 60 Hz: <ul style="list-style-type: none">• Denali, Dover, Tacoma Models
3	240 VAC Connections for North America 60 Hz: <ul style="list-style-type: none">• Denali, Dover, Tacoma Models

Ask your electrician to view the diagrams on the next few pages to ensure all connections are correct.

Important: When installed in the United States, the electrical wiring of this spa must meet the requirements of the National Electric Code (NEC) and any applicable state or local codes. The electrical circuit must be installed by an electrical contractor AND approved by a local building/electrical inspector.